

FABRICANT DE POÊLES INTERNATIONAL INC. 250, rue de Copenhague, Saint-Augustin-de-Desmaures (Québec) G3A 2H3 Tél : (418) 878-3040 Fax : (418) 878-3001 www.sbi-international.com			TOLÉRANCES FRACTION : ± 1/32" .XX : ±.020" .XXX : ±.010" ANGLES : ±0.5°	 THESE ALLOWANCES ARE NOT CUMULATIVE
NOM DE LA PIÈCE / PART NAME CHASSEUR /			RÉVISIONS / REVISIONS 1a -	
CONCEPTEUR -	DESSINATEUR J-P Alain	PAGE 3 de 5	DESSIN / DRAWING NBR DB00400-WEB	

Dimensions de la chambre à combustion	
Largeur:	12 7/16"
Profondeur:	19 7/8"
Hauteur:	12 15/16" à 16 3/16"

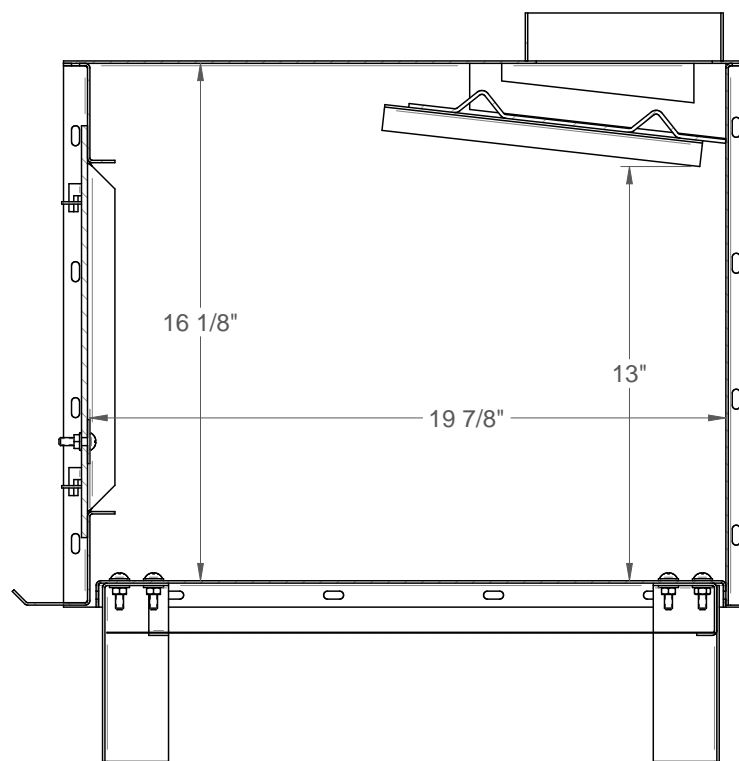

SECTION A-A

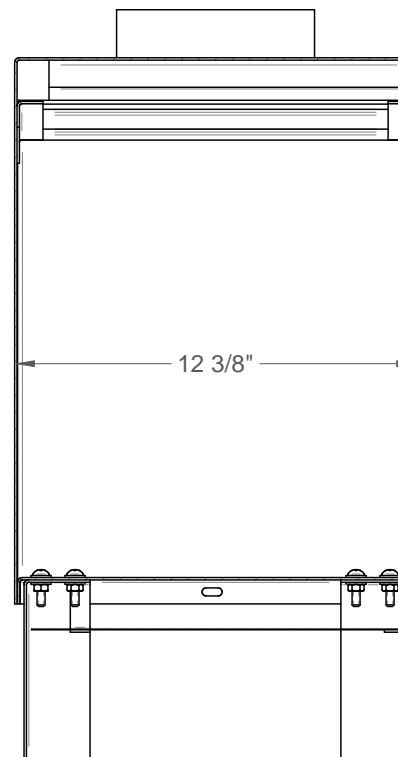



SECTION B-B

Volume de chambre à combustion: 3476.184 po³

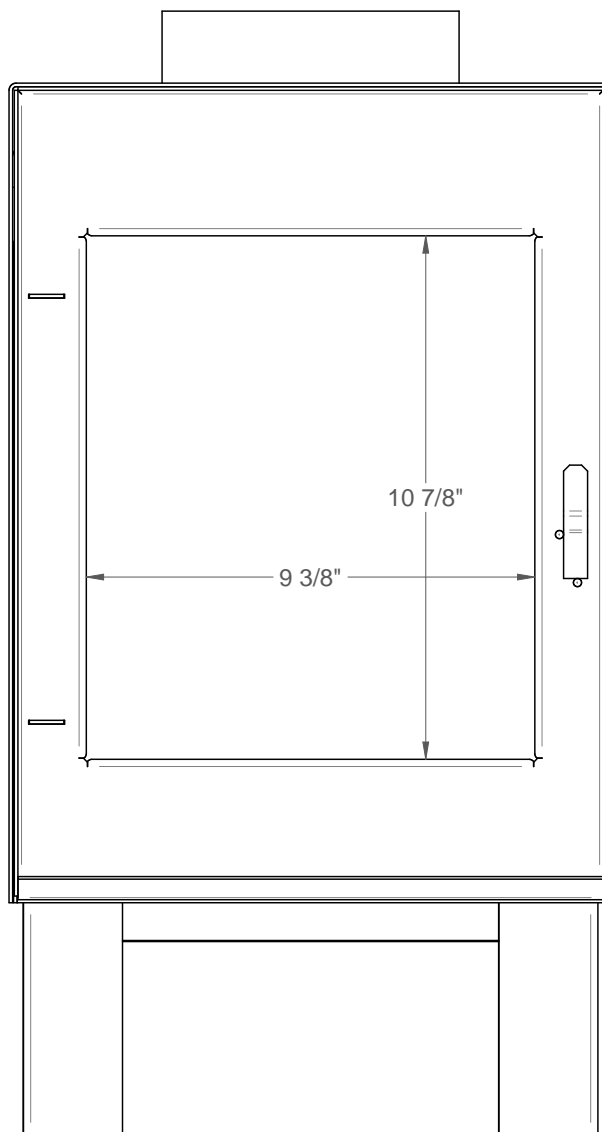
FABRICANT DE POÊLES INTERNATIONAL INC. 250, rue de Copenhague, Saint-Augustin-de-Desmaures (Québec) G3A 2H3 Tél : (418) 878-3040 Fax : (418) 878-3001 www.sbi-international.com		TOLÉRANCES FRACTION : ± 1/32" .XX : ±.020" .XXX : ±.010" ANGLES : ±0.5°	 THESE ALLOWANCES ARE NOT CUMULATIVE
NOM DE LA PIÈCE / PART NAME CHASSEUR /		RÉVISIONS / REVISIONS 1a -	
CONCEPTEUR -	DESSINATEUR J-P Alain	PAGE 4 de 5	DESSIN / DRAWING NBR DB00400-WEB

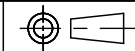

Dimensions de l'ouverture de porte	
Largeur	X
Hauteur	Y

FABRICANT DE POÊLES INTERNATIONAL INC. 250, rue de Copenhague, Saint-Augustin-de-Desmaures (Québec) G3A 2H3 Tél : (418) 878-3040 Fax : (418) 878-3001 www.sbi-international.com		TOLÉRANCES FRACTION : ± 1/32" .XX : ±.020" .XXX : ±.010" ANGLES : ±0.5°	 THESE ALLOWANCES ARE NOT CUMULATIVE
NOM DE LA PIÈCE / PART NAME CHASSEUR /		RÉVISIONS / REVISIONS  -	
CONCEPTEUR -	DESSINATEUR J-P Alain	PAGE 5 de 5	DESSIN / DRAWING NBR DB00400-WEB